



vibDOT | Data sheet

EFFECTICE AUGUST 2024

A compact multi-sensor node for pump monitoring, equipped with a 3-axis vibration sensor, enables precise detection of vibrations and temperature. The integrated magnetic field sensor also enables the detection of rotation speed, speed direction and offers start/stop detection.



Measured Values

- Temperature measurement: -30°C to 100°C ($\pm 1,6^{\circ}\text{C}$)
- Vibration measurement: effective value (m/s^2 , mm/s), crest factor, kurtosis factor, absolute maximum value, 5 configurable frequency ranges (peak, frequency, effective value)
- Motor speed detection, start/stop-detection
- Bandwith: 5 Hz to 5 kHz
- Amplitude: $\pm 2/\pm 4/\pm 8/\pm 16\text{ g}$
- Measuring interval: 500 ms

Operating Conditions

- Operating temperature: -30°C to 65°C
- Storage / transport temperature: -30°C to 75°C

Elektrical Data

- Voltage (PoE): 44 – 57 VDC (PoE IEEE802.3af)
- Max. Power Consumption: 1 W
- Protection Class: III

Housing

- HxWxD: 62,5x47x47 mm
- Weight: 275g
- Assembly: single-screw fastening M8
- Material: 303 stainless steel
- Protection class: IP65

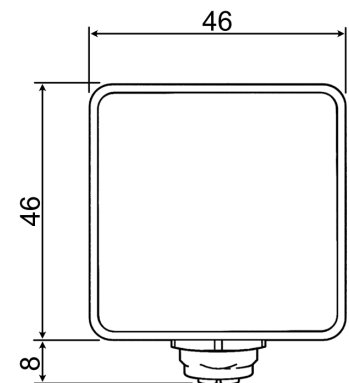
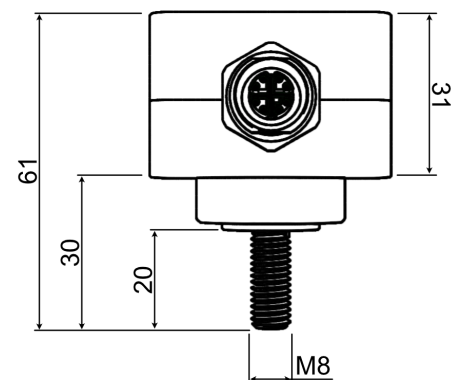

Interfaces and Outputs (digital)

- Ethernet
- Bluetooth 5.4

Communication Protocols

- OPC-UA** for communication with the control centre/control system
- MQTT** for communication with the cloud
- Bluetooth** for the connection with the app

Display Options on the vibDOT

- Status LED & Health LED: colour indication of current status (traffic light system), threshold values adjustable for user
- via digital interfaces

Other Components:

